



Product data sheet Pellet 8 mm

Barlinek WOODEN PELLETS

PRODUCT NAME:

"BARLINEK WOODEN PELLETS

INTENDED USE:

Pellet is wooden, solid biofuel intended for combustion in modern boilers, fireplaces and burners in order to generate heat energy for heating purposes (heating of single family houses, housing cooperatives, hotel and holiday centres, public utility centres, warehouses, industrial halls, religious buildings, sports halls and other facilities, larger or smaller, which require heat energy). Pellet may also be burned in oil boilers (replacing the oil burner with Pellet burner).

COMPOSITION:

Granules pressed in high temperature and pressure, made of dry, milled and clean wood shavings. Pellet 8 mm in diameter consists of 70% shavings from softwood and 30% of hardwood. The content of Pellet may change due to processed wood materials.

PRODUCT CHARACTERISTICS:

- High-calorific – about 4,9 kWh of 1 kilogram of Pellet (1 tonne of Pelletu replaces 470 litres heating oil, 572 m³ of natural gas, 429 L of LPG gas, 0.79 tonne of coal e.g. eco-pea)
- Small amount of ash remaining after combustion of Pellet ($\leq 0,6\%$);
- Easy to store (1 tonne of Pellet packed in 15kg bags takes up about 2 m³; Pellet in bulk takes up 1.7 m³);
- Eco-friendly (ash formed after burning the pellets can be used as a fertiliser for your lawn or garden);
- "Zero emissions of CO₂" - the amount of CO₂ that is produced during the combustion of Pellet is equal to the amount of CO₂ that growing plants absorb during photosynthesis;
- It does not contain harmful substances;
- It does not emit burdensome and unpleasant odours;
- It does not cause allergies;
- Ergonomically refined unit packaging;
- Clean in use - it does not leave dirt in rooms as other solid fuels do, such as coal (e.g. eco-pea coal), wood, coke, fine coal.

Product data sheet

Pellet 8 mm



DIMENSIONS:

Pellet	Ø 8 mm	length $3,15 \leq L \leq 40$
Deviation	Ø ±1 mm	maximum 1% of mouldings ≤ 45 mm

Tested feature	Testing method	Unit	Requirements of the standard EN Plus A1	Result for Barlinek Wooden Pellets*
Diameter	Measured with a vernier calliper	mm	8.0	8.0
Length	Measured with a vernier calliper	mm	$3,15 \leq L \leq 40$	$3,15 \leq L \leq 40$
Amount of total humidity	EN ISO 18134	%	≤ 10	≤ 8
Ash content (at 550 °c)	EN ISO 18122	%	$\leq 0,6$	$\leq 0,6$
Ash melting point	CEN/TS 15370	°C	≥ 1200	≥ 1400
Calorific value	EN ISO 18125	kWh/kg	$\geq 4,6$	$\geq 4,9$
Volume density	EN ISO 17828	kg/m ³	$600 \leq GO \leq 750$	≥ 660
Fine particle content (dust in a bag)	CEN/TS 15149-2	%	$\leq 0,5$	$\leq 0,5$
Abrasion (din plus)	EN ISO 17831	%	≥ 98	≥ 98

*Test results for 8 mm pellets based on the tests of the EN Plus Certification. Due to the variable characteristics of the raw material, the results of individual production batches may differ, but it must be within the requirements of the standard.

CERTIFICATES:

DIN Plus:

- No. 7A105 (Barlinek Inwestycje Sp. z o. o.) compliant with the International Standard ISO 17225-2
- No. 7A136 (Barlinek Invest LLC) compliant with the International Standard ISO 17225-2

EN Plus

- No. PL 003 (Barlinek Inwestycje Sp. z o. o.) compliant with the International Standard ISO 17225-2
- No. UA 001 (Barlinek Invest LLC) compliant with the International Standard ISO 17225-2



NR 7A105



NR 7A136



PL 003



UA 001

Product data sheet

Pellet 8 mm



PELLET LOGISTICS DATA Ø 8 mm

Unit weight of a bag [kg]	Pallet type	Number of bags in one layer [pc.]	Number of layers [pc.]	Number of bags on a pallet [pc.]	Sales units - pellet on a pallet with goods [kg]	Type of protection of a pallet
15	1,2 x 0,9	6	11	66	990	protective hood

UNIT PACKAGING

The product is placed on pallets of the following dimensions: 1.2 m x 0.9 m, that is protected from the outside with a protective foil hood

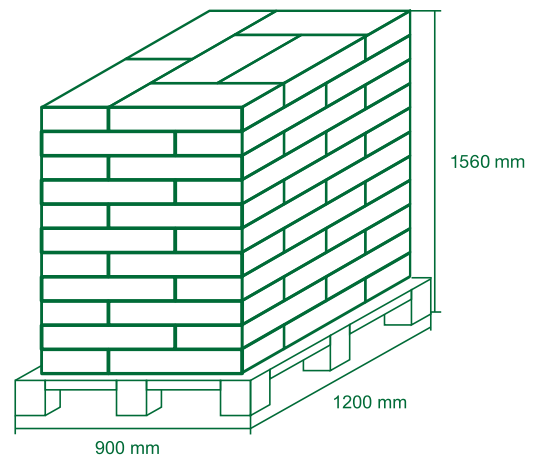

BIG BAG PACKAGING

Big bag packaging - 1000 kg

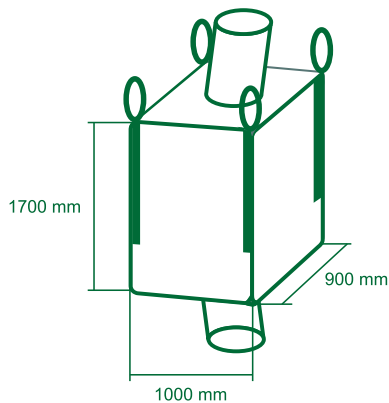

Pellet 8 mm in a big bag at the request of the buyer may be packed on a pallet 1,2 m x 0,9 m

TRANSPORT IN BULK

Transport of pellet in bulk up to 24 tons

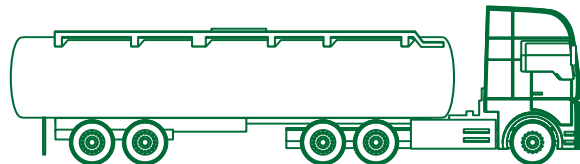

Product data sheet

Pellet 8 mm



TRANSPORT:

Pellet may be transported with covered means of road transport. The load should be placed and secured according to the transportation provisions regarding road transport. Full track load transport with curtain trailer, u-shaped trailer, tank trailer - up to 24 tons. WARNING: Possibility to purchase pellets in bulk - delivery terms: FCA, other conditions will be agreed individually.

While unloading Pellet from a tank trainer, the recommendations of the manufacturer are to be observed, i.e. proper outlet pressure should be applied.

STORAGE:

Barlinek recommends storing Pellet 8 mm in 15 kg bags in rooms complying with the following conditions:

- building with a roofing preventing vapour condensation on the inside; surface (sheet without thermal insulation);
- it is equipped with inlet/outlet gravitational or mechanical ventilation;
- the floor with tight moisture barrier;
- Pellet should be stored in a dry place, not exposed to direct impact of weather conditions.
- Pellet bags should be isolated from the ground by placing them on the pallets
- Permissible conditions for storage in warehouse facilities:
 - relative air humidity up to 65%
 - air temperature from +1°C to +28°C (from +34°F to +82°F).
- Formed pallets with 15 kg bags may be stored in stacks (one pallet on the other - maximum 2 layers). In such case it is recommended to use spacer boards (wood-based boards). The best solution is to place Pellet in layers in special warehouse racks.
- Pellet 8 mm in a big bag and in bulk must be absolutely stored in a warehouse hall in the conditions as above.

MANUCATURER:

BARLINEK S.A.
al. Solidarności 36
25-323 Kielce
POLAND

Phone: +48 41 333 11 00
Phone: +48 41 243 58 88

biuro@barlinek.com.pl
www.barlinekpellets.com

